

RK-UN-LU110 LED Work Light

Installation Manual



BEFORE YOU START Park on level ground, turn off the ignition, disconnect the negative battery terminal, and let components cool before installation.

Safety Information

- Park the vehicle on a level surface and engage the parking brake.
- Turn off the ignition and remove the key before installation.
- Disconnect the negative battery terminal to prevent electrical short circuits.
- Please wait until the bulbs and housings have completely cooled before handling them.

Tools Required

- Socket wrench set
- Phillips and flathead screwdrivers
- Trim removal tool
- Pliers (optional)
- Torque wrench

Wiring Diagram

This product features two working modes: Ambient Light and Key Light. Please match each wire according to its function. Before testing the vehicle lights, make sure all connections are secure.

If the DT connector on this LED light does not match the vehicle's original wiring harness, use the provided adapter harness to reconnect the wires / re-pin the connector, depending on the actual installation method.

①



DT Connector

②



Adapter Harness

③



Connecting Adapter

Adapter Harness

Negative ○-----○
Ambient Light ○-----○
Key Light ○-----○

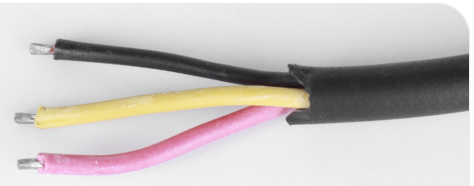

HOW TO INSTALL

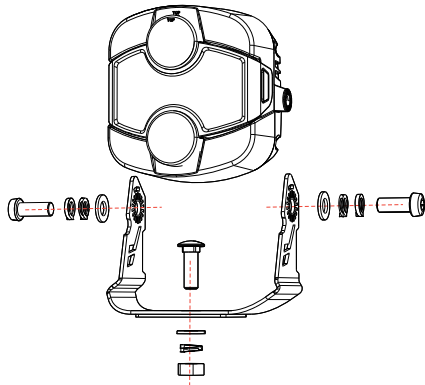

1 CHOOSE THE MOUNTING LOCATION

1

Select a secure mounting location such as the bumper, grille, roof rack, or bull bar. Ensure the light beam is unobstructed and there is sufficient space for wiring and angle adjustment.

2 MOUNT THE LIGHT

2

Position the light at the desired location. Insert the mounting bolt and tighten all hardware securely.

3 CONNECT THE WIRING

3

Connect the Positive (+) to the power source or switch, and connect the Ground (-) to a proper ground point. Ensure all connections are secure and insulated.

4 TEST THE LIGHT

4

Reconnect the vehicle battery. Test the light and adjust the beam if necessary.

FITMENT

- Universal

PRODUCT WARNINGS

Use with 9-32 V DC input. The light may become hot during continuous use. Avoid burns and allow cooling before service.

QUICK TROUBLESHOOTING

Issue: Flickering/intermittent light - check ground and plug connection.
Issue: No illumination - confirm 9-32 V input and battery connection.

**THANK YOU FOR CHOOSING
4x4 ROCKCATS!**

support@4x4rockcats.com
RK-UN-LU110 Installation Guide | Page 2

