

# RK-UN-LU09 Work Light Bar

## Installation Manual



**BEFORE YOU START** Park on level ground, turn off the ignition, disconnect the negative battery terminal, and let components cool before installation.

### Safety Information

- Park the vehicle on a level surface and engage the parking brake.
- Turn off the ignition and remove the key before installation.
- Disconnect the negative battery terminal to prevent electrical short circuits.
- Please wait until the bulbs and housings have completely cooled before handling them.

### Tools Required

- Socket wrench set
- Phillips and flathead screwdrivers
- Trim removal tool
- Pliers (optional)
- Torque wrench

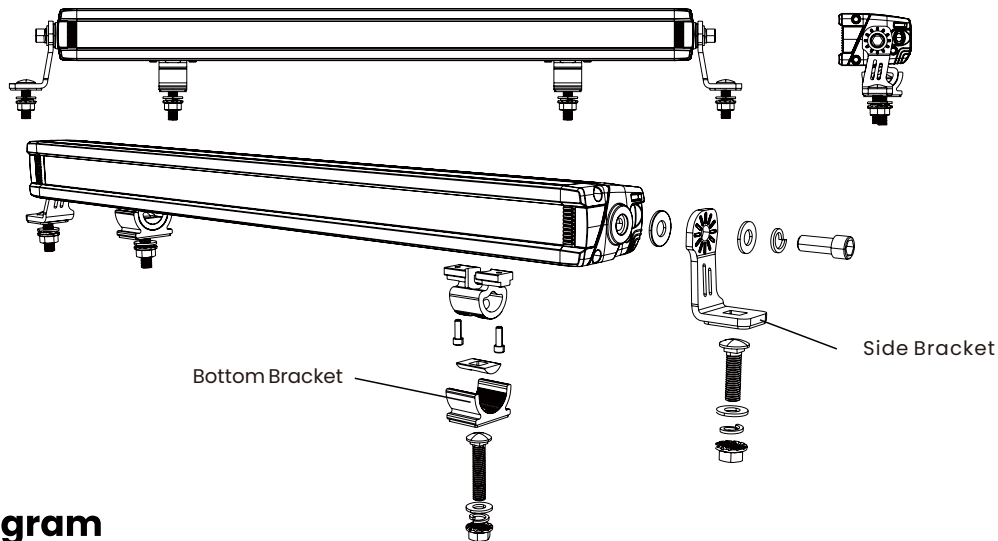

### Wiring Diagram

Match each wire by function. Secure every connection before testing the vehicle light bar.

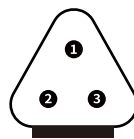
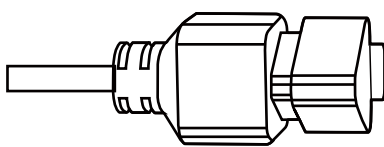

- ① --- Negative
- ② --- Work Light
- ③ --- Position Light

# HOW TO INSTALL



1

Turn off the engine before installation.

2

Install the mounting brackets onto the desired mounting location. Secure the Light bar with the supplied hardware.

3

Connect the light wires to a suitable power source according to your vehicle setup.

4

Route and secure all wiring away from moving parts, sharp edges, and heat sources. Test the light bar operation after installation.

## FITMENT

Universal — Fits Various Vehicles

## PRODUCT WARNINGS

Use with 9-32 V DC input. The light may become hot during continuous use. Avoid burns and allow cooling before service.

## QUICK TROUBLESHOOTING

Issue: Light does not turn on - Check the relay, fuse, and switch. Verify 9-32 V input.  
Issue: Light flickers - Tighten all connections and check the ground wire.  
Issue: Only one color works - check the wiring for that color channel.  
Issue: Light overheats - Check the wire gauge. Do not exceed the rated power.

**THANK YOU FOR CHOOSING  
4x4 ROCKCATS!**

support@4x4rockcats.com  
RK-UN-LU09 Installation Guide | Page 2

